

GO-PED® ACCESSORIES LIST

PART#	DESCRIPTION
9058	Canvas Carry Bag
9061	Tool Kit
9062	Go-Mix (Go-Ped Oil Pack)
9063	Go-Ped T-Shirt (M,Lg,XLg)

GO-PED® PARTS LIST

PART#	DESCRIPTION
1001	Frame
1002	Latch Assembly
1006	Wooden Deck
1007	Deck Hardware Kit
1013	Drive Spindle
1014	Drive Spindle Belt
1018	Engine Hardware Kit
1019	Frame / Muffler Connect Tube
1021	Gas Tank Hardware Kit
1022	Handle Lock Tube
1027	Front Fork
1028	Front Fork Bearing Kit
1030	Front Brake Caliper
1031	Front Axle Assembly
1032	Quick Release Axle Assy.
1034	Kick Stand
1039	Wheel Bearings
1043	Handle Hinge FTG Assembly
1046	"T" Handle
1047	Brake Lever Assembly
1049	Grip Set
1050	Throttle Cable Assembly
1051	Throttle Lever
1053	Plastic Cable Tie Set
1054	Brake Cable Assembly
1056	Handle Hinge Pin
1059	Wheel & Tire Assembly
1062	Automatic Safety Spring & Grip Kit
3114	Enduro Tank
3116	Gas Cap
3120	Fuel Filter Assembly

GO-PED® FRAME PARTS

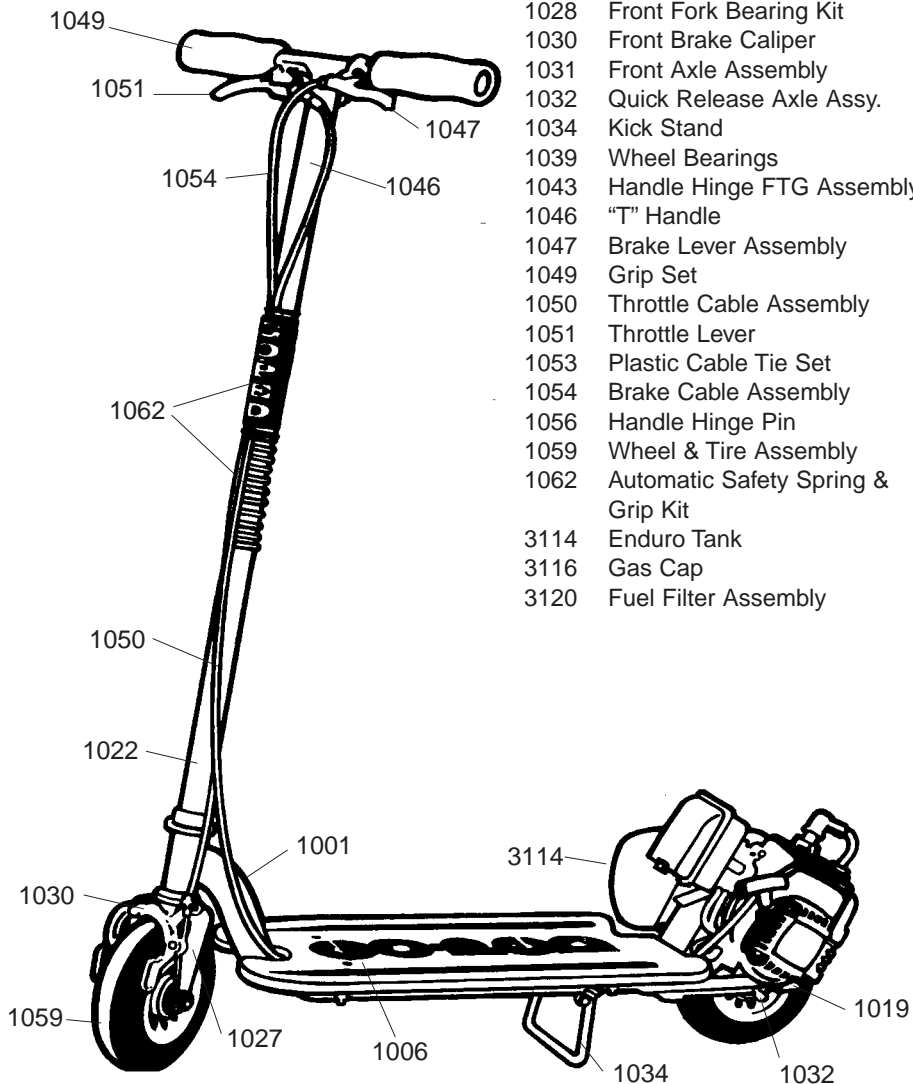

California
GO-PED®
 Brand Scooters

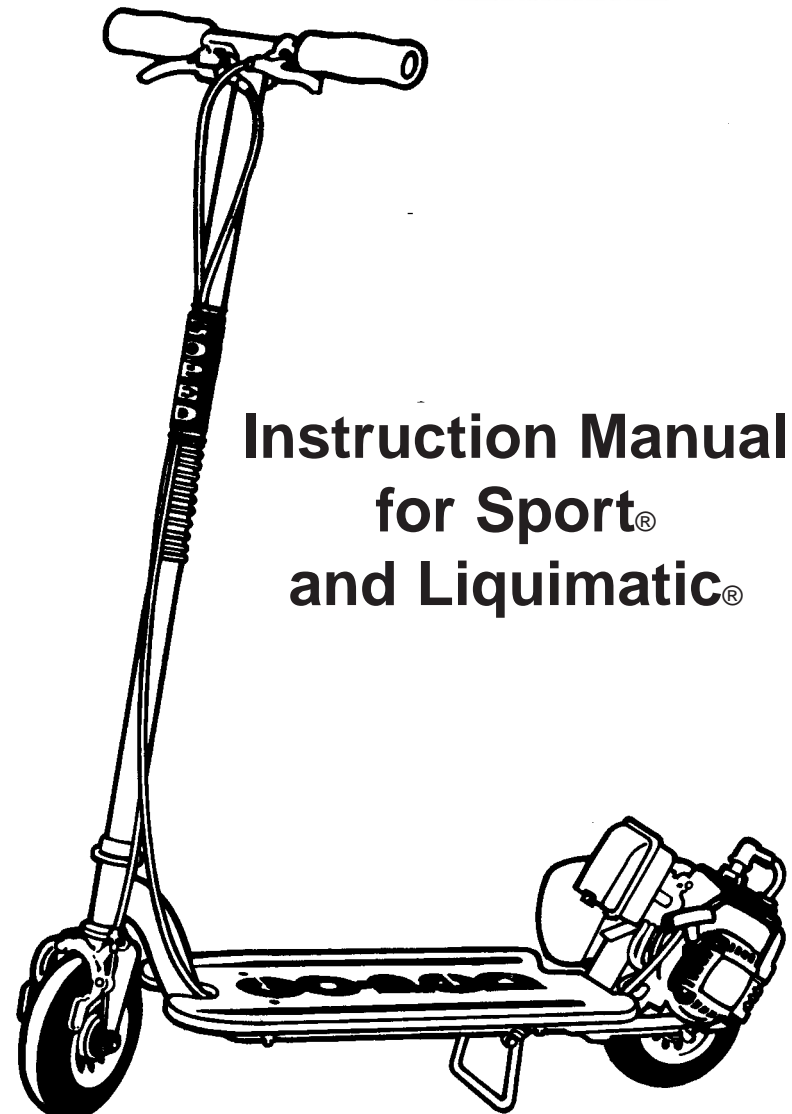

Instruction Manual for Sport® and Liquimatic®

Copyright 1999 Patmont Motor Werks. All Rights Reserved.

OIL & FUEL INFORMATION

BE SURE TO READ THESE INSTRUCTIONS CAREFULLY BEFORE ATTEMPTING TO START OR OPERATE THIS UNIT.

Using old or improper fuel, or improperly mixing the oil and fuel can cause engine damage. This type of damage will void engine warranty.

The Go-Ped® has a two-stroke engine that requires oil to be mixed with the gasoline. Use a high quality two-cycle oil that is formulated for small air-cooled engines. Go-Mix® oil comes in gallon and tank size packets for a proper mix every time. Go-Mix is available from your authorized Go-Ped® reseller and is the factory recommended oil for the all two stroke Go-Ped® products.

OIL AND FUEL MIXING INSTRUCTIONS

NOTE: For proper engine operation and maximum reliability, pay strict attention to the oil and fuel mixing instructions. Use a 40:1 fuel/oil ratio. Using improperly mixed fuel can severely damage the engine. Use the following procedure to ensure complete mixing:

1. Put a small amount of fresh gasoline into a clean 1 (U.S.) gallon (3.785 liter) fuel can.
2. Add 3.2 ounces of 2-cycle oil.
3. Fill the remainder of the fuel can with gasoline (1 gallon).
4. Screw the fuel can cap on tightly and SHAKE THE CAN VIGOROUSLY FOR 30 SECONDS.

Technical Support Hotline (925)373-7827

ENGINE PARTS FOR G23-LH ENGINE

Index	Part #	Description	Index	Part #	Description
	4800	Engine	41	4041	Crankshaft Complete
1	4001	Cylinder	44	3044	Flywheel Nut
2	4002	Muffler Bolt	45	4045	Cover Screw
3	4003	Cylinder Gasket	54	4054	Flywheel
4	4004	Cylinder Screw	55	4055	Ignition Coil
5	4005	Insulator Gasket	58	4058	Coil Screw
6	4006	Insulator Manifold	59	4059	Cord Complete
7	4007	Carburetor Gasket	60	4060	Grommet
8	4008	Insulator Screw	61	4061	Coil Screw
9	3009	Carburetor Screw	66	3066	Spark Plug
11	4011	Muffler Gasket	67	4067	Starter Assy
12	4012	Muffler	76	4112	Cap (plug)
16	4016	Crankcase	77	4113	Spring
18	4018	Crankcase Gasket	79	4079	Starter Screw
19	4019	Oil Seals Set	81	4115	Cap (seal)
20	3020	Main Crank Bearing Set	88	4088	Carburetor Assy.
21	3021	Snap Ring	107	3107	Cleaner Assy.
22	3022	Flywheel Key	108	3108	Filter Screen
23	4023	Crankcase Screw	109	3109	Air Filter
26	4026	Fan Cover	110	3110	Cover Cleaner
32	4032	Fan Cover Screw		3114	Gas Tank Assy.
33	4033	Engine Cover	111	3111	Rear Filter Housing
34	4034	Cover Screw	112	3117	Gas Cap Packing
35	3035	Piston	116	3116	Gas Cap Assy.
36	3036	Piston Rings Set (2)		3123	Kill Switch
37	3037	Piston Pin		3120	Fuel Filter
38	3038	Snap Ring Set			
39	3039	Pin Bearing			
40	3040	Pin Washers			

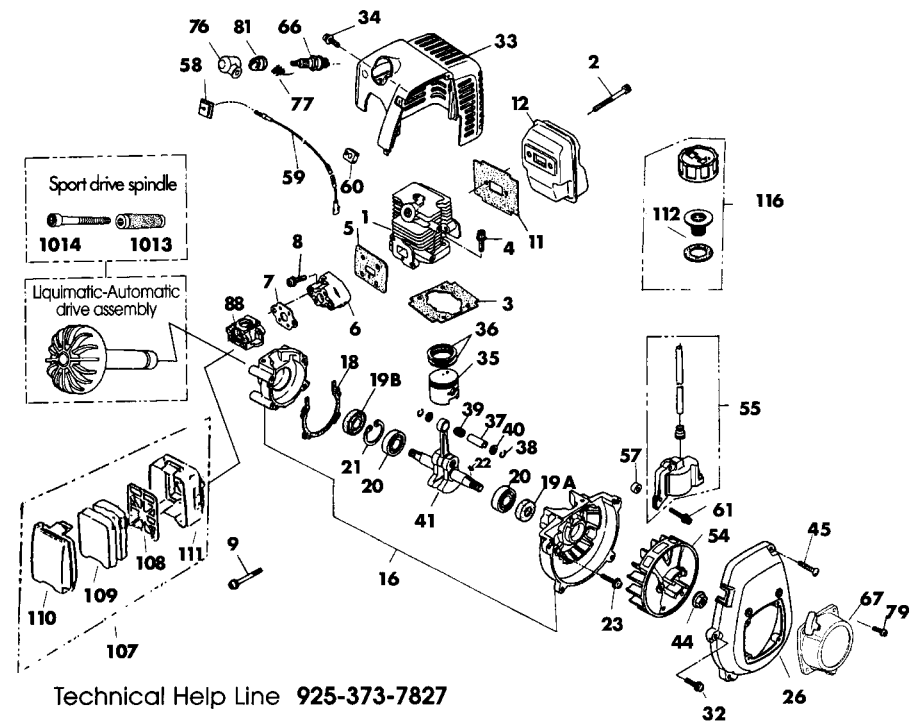

HOW TO ADJUST THE REAR WHEEL

1) Open quick release axle to unlock and allow free movement of wheel (wing nut may need to be loosened also).



2) With Quick Release Axle opened and loosened, rotate purple engine protection washer (EPW) down, away from rear gas tank support stud.



3) Apply up to 75 lb of weight to rear part of Go-Ped® deck (one knee on the “D” works pretty good) with rear wheel on the ground. (To apply proper wheel/spindle contact).



4) Rotate engine protection washer (EPW) up to contact rear gas tank support stud while weight is still applied, this will prevent overload to engine bearings and crankshaft.



5) Lock Down quick release lever with snug pressure. This will lock axle in position until readjustment is required.



FUELING AND PRE-OPERATIONAL

- Gasoline is extremely flammable and its vapors can explode when ignited. Always stop the engine and allow it to cool before filling the tank. Keep sparks and open flames away from the area.
- Add fuel in a clean, well-ventilated area. Avoid spilling the fuel when mixing the oil. Wipe up spilled fuel immediately. If fuel has been spilled allow it to dry completely before starting the engine.
- Move unit at least 10 ft. (3 m) from the fueling point before starting the engine.
- Pressure can build up in the fuel tank. Loosen the fuel tank cap slowly to relieve any pressure in the tank.
- Store gasoline and fuel only in containers designed and approved for the storage of such materials.

FOLDING FEATURE

BEFORE YOU RIDE - Be certain the handle lock tube is in its full down position, locking the handle bar upright. The latch hook on the rear fender locks the handle in the folded position for carrying or storage.

CONTROLS

BEFORE YOU RIDE - familiarize yourself with how your Go-Ped® works.

- The left-hand lever operates the front wheel caliper brake, and stops the engine when approaching 2 mph. Or less. Upon deceleration, the engine itself will act as a rear brake via engine compression.
- The right hand lever operates the engine throttle. The red button is the engine kill switch, and usable for rear wheel braking.

- The handlebar supports the rider and steers the Go-Ped®, just like a bicycle.
- Always use both hands on the handlebar when riding.

SAFE BRAKING

- 1) Your Go-Ped® is capable of going up very steep hills and is therefore equipped with a VERY effective braking system through the use of your front brake in conjunction with engine compression that acts as an anti-skid rear brake.
- 2) Your Go-Ped® is designed to be as compact as possible, so therefore has a short wheelbase.

Because of 1) and 2) mentioned above it is very important to understand that your body weight and distribution plays a key role in your riding safety and overall control of your Go-Ped®.

- When braking, using the primary front wheel brake control lever located on the left side of handlebar, always LEAN BACK enough to resist forward inertia as to keep REAR wheel on the ground.
- The engine kill button, located on the handlebar, serves as a rear anti-skid brake control.

SAFE ACCELERATING

When accelerating, using throttle control lever located on the right side of handlebar, always LEAN FORWARD enough to resist rearward inertia as to keep the front wheel on the ground.

LIQUIMATIC® GO-PED® INSTRUCTIONS

The Liquimatic® Go-Ped® is equipped with a revolutionary hydraulic torque converter transmission designed and patented by the engineers of Patmont Motor Werks. The purpose of the Hydraulic Torque Converter on the Liquimatic® is to greatly increase the user friendliness and to ease operation of the Go-Ped®.

Each unit is assembled, sealed and tested before shipment from the factory. Any problems or questions should be referred to the factory technical support help line found below.

Starting procedure is similar to the standard Sport Go-Ped®. Once running, keep the front break caliper applied with front wheel firmly on the ground to prevent the Liquimatic from rolling forward. At engine idle there will be a gentle tug, which is normal.

Simply stand on the Liquimatic® Go-Ped®, release the brake, gently squeeze the throttle and accelerate to a comfortable speed.

Deceleration and stopping is similar to the standard Sport Go-Ped®, using the front wheel braking, but with a much smoother stop, as the engine remains at idle.

NOTE: As engine power is applied through a friction drive roller to the tire surface it is very important to maintain proper tire/drive roller adjustment as outlined in this manual.

Technical Support Hotline (925)373-7827
On the internet - www.goped.com

FREE WHEEL SCOOTING

Unlock the rear wheel quick release lever. Pull wheel down to bottom of axle adjustment slot. Rotate EPW to contact lug and lock down Quick Release Lever. Check for free rotation of rear wheel. Riding in this mode should be legal anywhere bicycles are allowed.

NOTE: Rear wheel adjustment will be required more frequently when tire is new, to prevent drive system slippage. If drive system is allowed to slip excessively, high temperatures will result and damage the drive spindle, extreme or uneven tire wear will also result, causing uneven overloading to engine crankshaft and bearing. Refer to "How to adjust the rear wheel" section in this manual to correct drive system engagement issues.

MAINTENANCE / PARTS AND TIRES

- Parts and service are also available through your Go-Ped® dealership. To locate a dealer closest to you visit our web site - www.goped.com or call the technical support line - 925-373-7827.
- Use only manufacturer's original equipment replacement parts when servicing this unit. These parts are available from your authorized Go-Ped® dealer. The use of non-standard parts, or other accessories or attachments not designed for this unit could result in serious injury to the user, damage the unit and / or void all warranties.

TIRES

Non-pneumatic tires require no maintenance but must be replaced when normal wear and tear makes the tire diameter reach the wear limit dimple found on the side wall of the tire. Split, cracked or torn tires should be replaced immediately.

Technical Support Hotline (925)373-7827

TIPS

BEFORE YOU RIDE-

- Thoroughly inspect the unit for loose or damaged parts before each use. Do not use until adjustment or repairs are made.
- New engine break in period is a few hours, so avoid full throttle operation during this time.
- Position your feet in any location that is comfortable to you. Most prefer a parallel stance with the left leg slightly behind the right and bearing most of the weight, lean back slightly and your Go-Ped® will handle much like water skiing.
- Keep the air intake clear of debris.
- Do not touch the muffler or cylinder these parts get extremely hot from operation and remain hot for a short time after the equipment is turned off.

DRIVING DEFENSIVELY

Although the engine noise has been reduced, it is difficult to hear vehicles approaching you - head check often and before changing direction. The Go-Ped® has been designed to operate on any hard pack, dry smooth surfaces: avoid wet and or oily surfaces, loose sand, gravel, pot holes, etc. Always use both hands on the handle when riding.

- Do not wear loose fitting clothing or articles such as scarves, strings, chains, ties, etc.

STARTING

STARTING INSTRUCTIONS

- 1) Pump primer bulb until fuel flows steadily through clear overflow tube.
- 2) Move choke lever to the closed position.
- 3) Set throttle to start position (half).
- 4) Pull starter until engine starts.
- 5) Allow engine to warm up before using.
- 6) To stop, idle engine, push red kill button.

BEFORE YOU RIDE - The Go-Ped® should be warmed up. Simply use the center stand, so that the rear wheel is off the ground, and place your foot on the deck while you pull the pull-start handle. After warming up the engine (30 seconds to one minute), kill the engine by depressing the red kill button. Now the Go-Ped® can be compression push started (this may take a little practice, but adequate skill should be come within a couple of hours) Holding on to the hand grips, with the throttle off, briskly push the Go-Ped® forward, then step on the deck (requires at least 70 lbs.) with one straight leg after pushing off with the other. It may require a few kicks to get the engine started, but once its running you may put your other foot on the deck and accelerate. All this may be easier on a slight downhill grade until you have your technique down. An accomplished rider can get under way in one single natural motion.

MOTORIZED RIDING

Power transmission is through a drive spindle connected directly to the engine crankshaft. The rear wheel must be engaged to the engine drive spindle for motorized operation. Your Go-Ped® is shipped with the rear wheel in the engaged position. The rear wheel may be engaged / disengaged by use of the **quick release axle**. If the rear wheel is incorrectly adjusted, slippage of the friction drive spindle will greatly increase rear tire wear and prevent compression push starts. Refer to “How to adjust rear wheel” section of this manual to correct drive system slippage.

Operate this unit only in a well-ventilated area outdoors - carbon monoxide exhaust fumes can be lethal in a confined area.

NOTE:

- The status of the Go-Ped® as a “motor vehicle” is subject to drivers licensing, insurance requirements and registration which varies from state to state.
- You should check with a reliable authority in your state to see if the Go-Ped® must be registered as a motor vehicle. Your police department or local department of motor vehicles may be able to answer your questions or direct you to a reliable authority.
- Your insurance policies may not provide coverage for accidents involving the use of this vehicle. To determine if coverage is provided you should contact your insurance company or agent.
- The **recommended age** and **minimum weight** for the Go-Ped® is **16 years or older and 100 pounds**, but this is subject to the physical coordination of the rider, the ability of the rider to wear protective gear and to take responsibility for their own actions.

▲ WARNING

⊗ CARS ⊗ CHILDREN ▲ FALLING ⊗ HELMET ⊗ GLOVES ⊗ GOGGLES ⊗ SHOES

- This vehicle does not conform to Federal Motor Vehicle Safety Standards and is not intended for operation on public streets, roads or highways.
- This product should never be used by minors without adult supervision.
- The user of this product assumes all risks associated with its use.
- The operator can minimize assumed risk by wearing a safety helmet, goggles, gloves, elbow pads, knee pads and shoes with ankle support.
- Do not operate unless you have excellent vision, balance, coordination, reflexes, muscle and bone strength and good decision making capability.
- Do not operate this vehicle in traffic, or on wet, frozen, oily or unpaved surfaces.
- Avoid uneven surface, chuckholes, surface cracks and stationary or moving obstacles.

Technical Support Line - 925-373-7827